

Bronze Check Valves PN20/300PSI/Class150

Horizontal Swing
BSEN12288, Threaded Ends Comply to BS21 or ANSI 2.1

Hydraulic Pressure Test	
Body	3.0Mpa/30Bar
Seat	2.2Mpa/22Bar

Pressure Ratings	
0.9 Mpa at 180°C	
2.0 Mpa at -20°C-100°C	



C107
1/2" - 4"

Materials List

No	Part	Specification	BS EN	ASTM
1	Body	Cast Bronze	1982 CC490K	B584 C84400
2	Disc	Cast Bronze	1982 CC490K	B584 C84400
3	Bonnet	Cast Bronze	1982 CC490K	B584 C84400
4	Hanger Pin	Brass	12164 CW603N	B16 C36000
5	Plug	Brass	12164 CW603N	B16 C36000

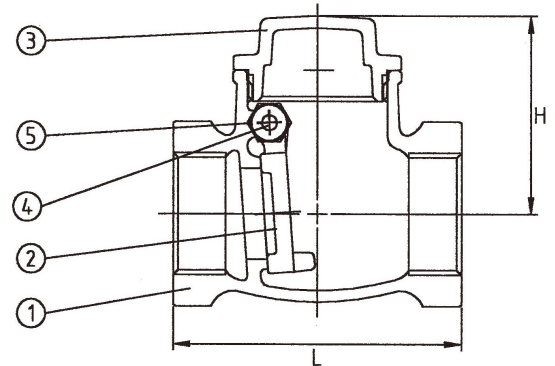

Dimensions-Weights

mm	15	20	25	32	40	50	65	80	100	
In	½	¾	1	1¼	1½	2	2½	3	4	
L	56	70.5	80	96.5	110	129	138	151	178	
H	39.5	42.5	50	55	60	69.5	90	100	114	
Weight	Lbs	0.51	0.64	0.95	1.43	1.79	2.95	6.06	8.38	13.12
	Kg	0.23	0.29	0.43	0.65	0.81	1.34	2.75	3.80	5.95

* TALOAR Check Valves may be installed in both horizontal and vertical lines with upward flow or in any intermediate position.

Each TALOAR bronze valve has been thoroughly cleaned and degreased and packed separately in the sealed polythene bag.